

# GIORNATA DI STUDIO "IDROGENO E TECNOLOGIE PER LA GENERAZIONE ENERGETICA E LA PROPULSIONE NEI TRASPORTI GREEN"

Villa Giustiniani-Cambiaso, Aula A7 «Oreste Acton» Via Montallegro 1, Genova.

DIME Dipartimento di Ingegneria Meccanica, Energetica, Gestionale e dei Trasporti, Università di Genova, 25 gennaio 2024.

## Design, control and diagnostics of hydrogen-based energy systems

Pierpaolo Polverino, Cesare Pianese, Marco Sorrentino, Mariagiovanna Minutillo

Energy and Propulsion Laboratory (EProLab)

Dipartimento di Ingegneria Industriale

Università degli Studi di Salerno



UNIVERSITÀ DEGLI STUDI  
DI SALERNO



## INTRODUCTION

**Cesare Pianese**, Full Professor **PEOPLE**  
**Mariagiovanna Minutillo**, Full Professor  
**Marco Sorrentino**, Associate Professor  
**Pierpaolo Polverino**, Assistant Professor  
**Gianfranco Rizzo**, Full Professor (ret.)  
**Ivan Arsie**, Full Professor (UniParthenope)  
**Luigi Maritato**, Full Professor (Appl. Phys.)  
**Alice Galdi**, Associate Professor (Appl. Phys.)  
**Ennio Adinolfi**, Research fellow  
**Davide Cervone**, Research fellow  
**Paolo Aliberti**, Ph.D. Student  
**Giovanni Bove**, Ph.D. Student  
**Marco Califano**, Ph.D. Student  
**Maria Rosaria Crispi**, Ph.D. Student  
**Antonio Foglia**, Ph. D student  
**Alfonso Pandolfi**, Ph.D. Student  
**Massimo Sicilia**, Ph.D. Student  
**Gianpaolo Noschere**, Technician

## KEY WORKS & RESULTS

### SOME PARTNERS

TIM  
SOLYDERA  
MARELLI  
INWIT  
SUNFIRE FUEL CELLS  
THE OHIO STATE UNIVERSITY  
ETH  
EPFL  
EIFER  
VTT  
AALBORG UNIVERSITY  
LINKOPING UNIVERSITY  
CEA-LITEN  
UBFC  
... AND OTHERS

## RELEVANT PUBLICATIONS

### Working Areas

### EXPERTISE

- Internal Combustion Engines
- Proton Exchange Membrane Fuel Cells
- Solid Oxide Cells (Fuel/Electrolyser)
- Hybrid-electric powertrains
- Models for monitoring, diagnosis, prognosis, control and optimization
- EMS for HEV and Multi-Energy Systems
- Electrochemical Impedance Spectroscopy
- Solar-powered HEV

### Facilities

- 1 Engine test bench
- 1 Fuel Cell test bench
- SOFC button-cell test oven
- AVL Puma automation system
- AVL battery emulator
- Zhaner EIS analyser

### 3 Spin-off & Innovative Start-ups

### 5 Patents

### 14 European Project (3 as Coordinator)



ICE & FC TEST BENCHES AT EPROLAB (UNISA)

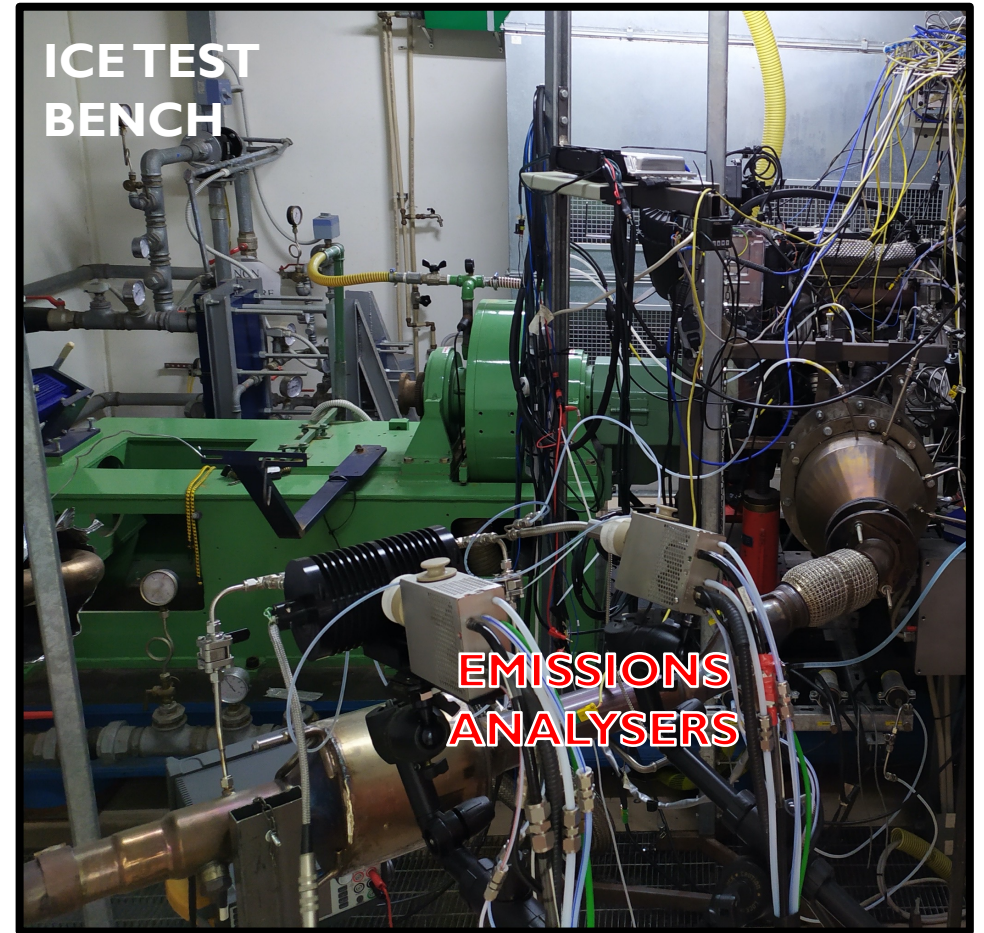
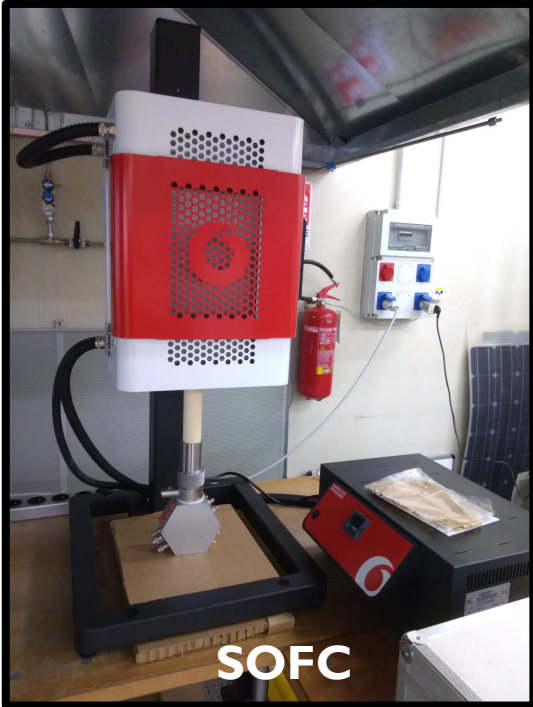
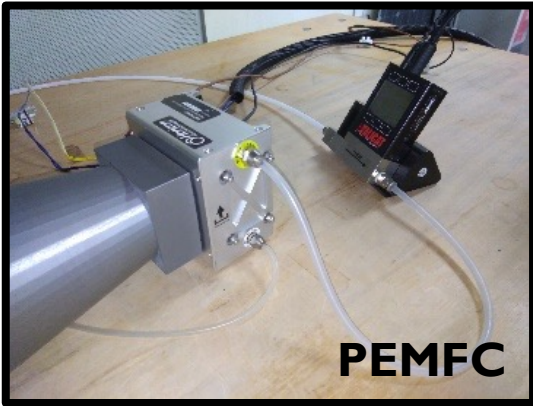

5 ONGOING

9 CLOSED

## EUROPEAN PROJECTS

2023-ongoing | **HECATE** | Hybrid Electric regional Aircraft distribution TEchnologies

2022-ongoing | **NEWMANN** | Novel Energy and propUlsion systeMs for Air dominance

2022-ongoing | **FUELSOME** | Multifuel SOFC system with Maritime Energy vectors

2021-ongoing | **REACTT** | Reliable advance diagnostics and control tools for incremented lifetime of Solid Oxide Cell technology

2020-ongoing | **RUBY** | Robust and reliable general management tool for performance and dUraBility improvement of fuel cell stationarY units | **Coordinator.**

2020-2023 | **NewSOC** | Next Generation solid oxide fuel cell and electrolysis technology

2019-2022 | **AD ASTRA** | HAarnessing Degradation mechanisms to prescribe Accelerated Stress Tests for the Realization of SOC lifetime prediction Algorithms

2017-2019 | **INSIGHT** | ImplementatiON in real SOFC Systems of monItoring and diaGnostic tools using signal analysis to increase tHeir lifetime

2015-2018 | **HEALTH CODE** | Real operation pem fuel cells HEALTH-state monitoring and diagnosis based on dc-dc COnverter embeddeD Eis | **Coordinator.**

2014 -2017 | **DIAMOND** | Diagnosis-aided control for SOFC power systems

2013-2015 | **PUMA MIND** | Physical bottom Up Multiscale Modelling for Automotive PEMFC Innovative performance and Durability optimisation

2011-2014 | **D-CODE** | DC/DC COnverter-based Diagnostics for PEM systems | **Coordinator.**

2011-2013 | **DESIGN** | Degradation Signatures identification for stack operation diagnostics

2010-2013 | **GENIUS** | Generic Diagnosis Instrument for SOFC Systems



DESIGN OF A MODEL-BASED DIAGNOSTIC ALGORITHMS FOR SOFC SYSTEMS

Objective & Innovation

Develop a **model-based diagnostic algorithm** based on heuristic knowledge, conventional measurements and physical modelling for **on-board diagnosis** of SOFC systems.



DIAGNOSTIC FRAMEWORK

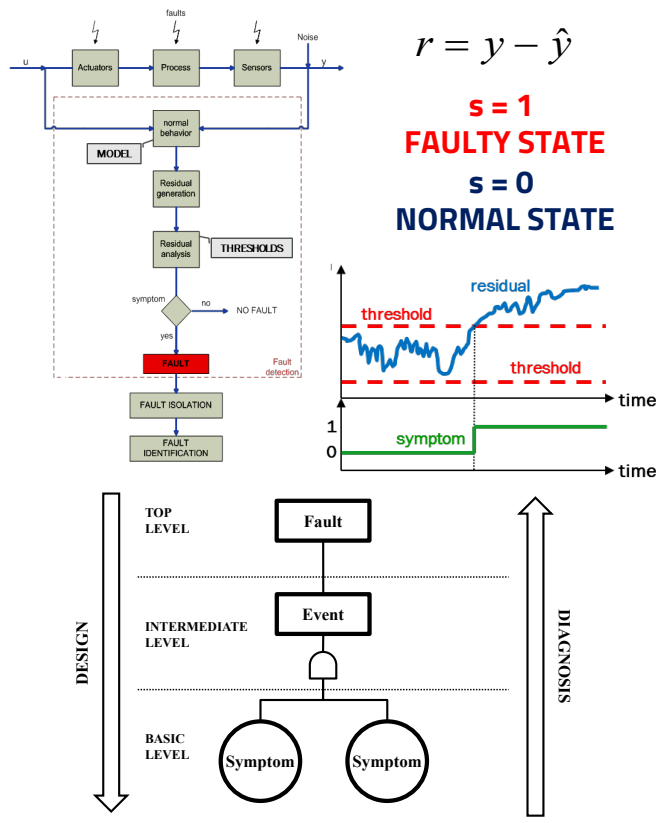

SYSTEM AND FAULTS MODELLING

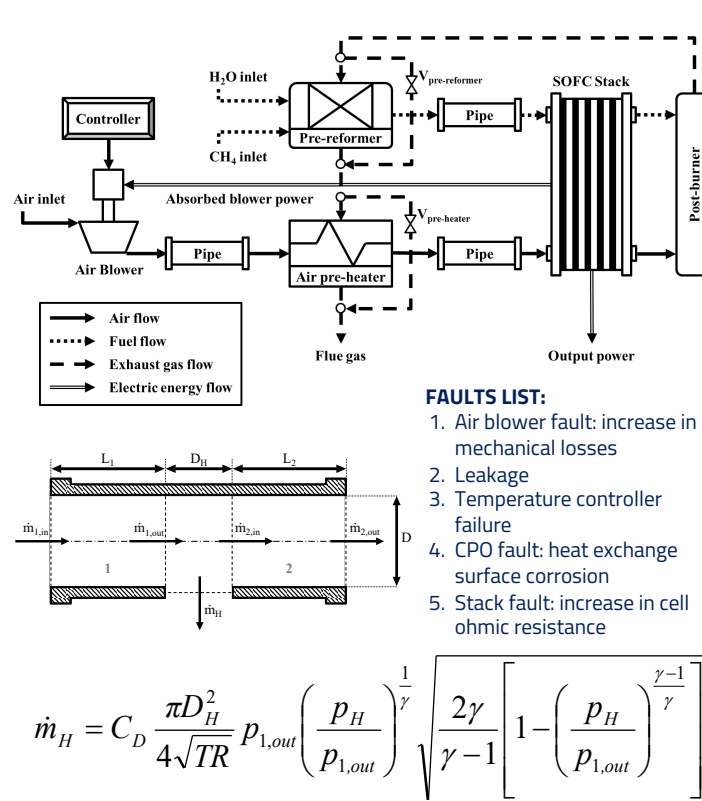

SIMULATION RESULTS

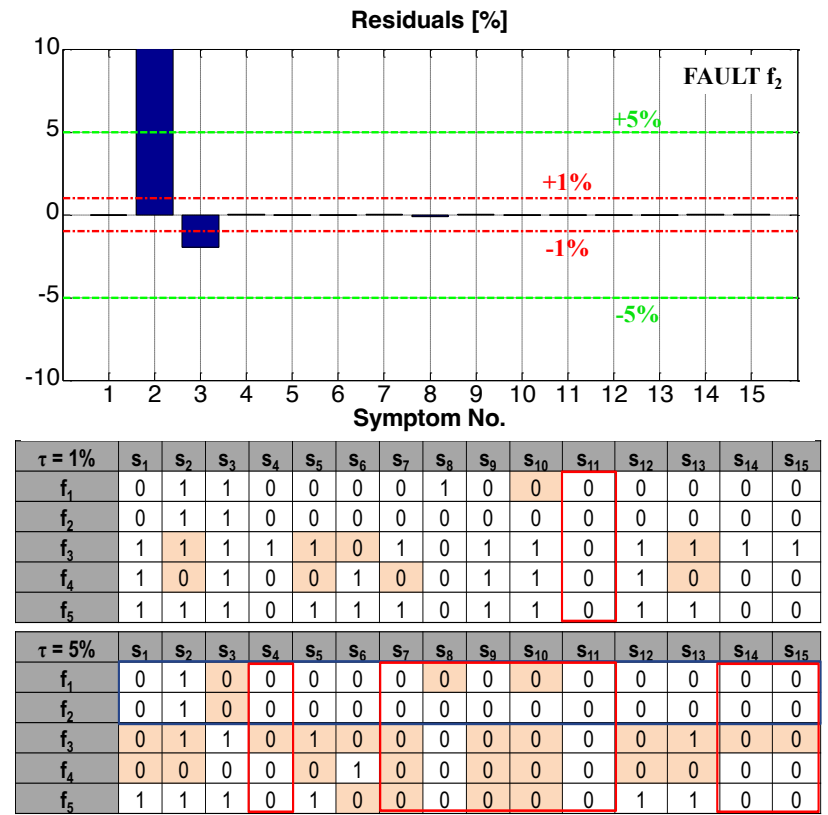

Polverino P., Pianese C., Sorrentino M., Marra D., Model-based development of a fault signature matrix to improve solid oxide fuel cell systems on-site diagnosis, Journal of Power Sources 280 (2015) 320-338.



DESIGN AN EIS-BASED DIAGNOSTIC ALGORITHMS FOR PEMFC and rSOC

Objective & Innovation

Design an **EIS-based diagnostic algorithm** through Equivalent Circuit Modelling with **automatic parameters identification** for on-board diagnostic of **PEMFC and rSOC**.



METHODOLOGY INVESTIGATION

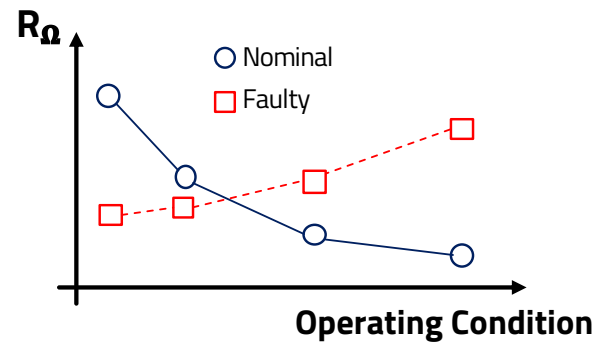
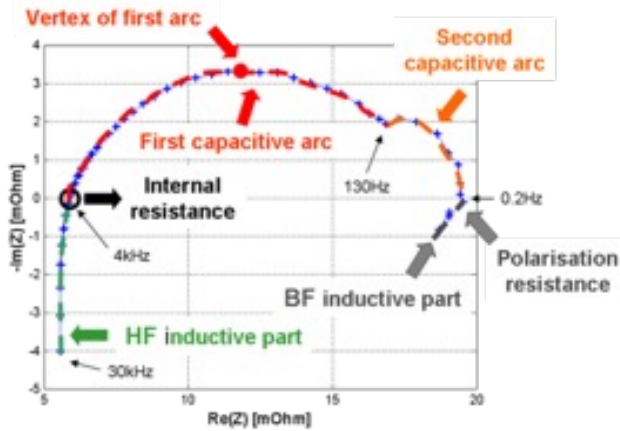

PATENTED ALGORITHM

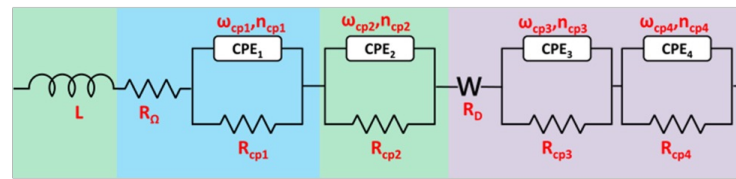

Usually Present    Always (Fixed)    Automatically enabled if necessary

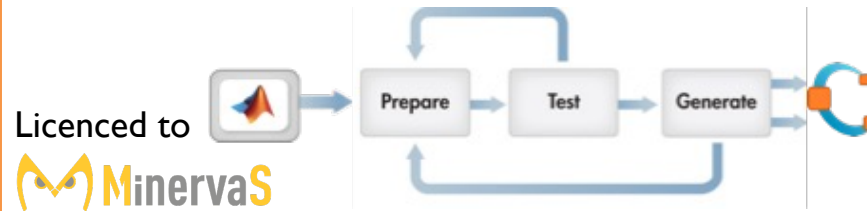
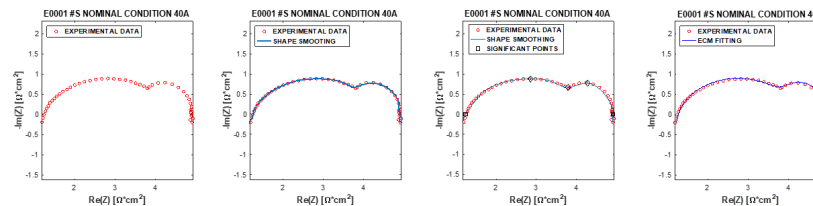

ON-BOARD VALIDATION

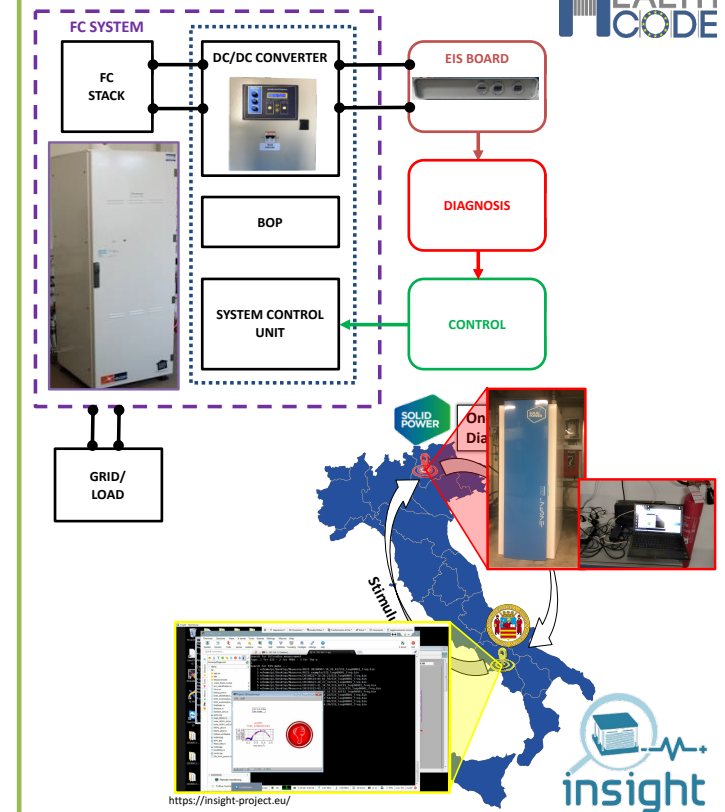

Petrone R., Pianese C., Polverino P., Sorrentino M., Method and Apparatus for Monitoring and Diagnosing Electrochemical Devices based on Automatic Electrochemical Impedance Identification (2016) International Publication Number WO 2016/071801, PCT/IB2015/058258.



DESIGN A DEGRADATION-AWARE PROGNOSTICS AND CONTROL ALGORITHM FOR PEMFC SYSTEMS

Objective & Innovation

Develop through **multiscale modelling** approach a **simplified degradation model** to design a **degradation-aware algorithm** for **on-board prognostics and control** applications on PEMFC systems.



PT DISSOLUTION MODELLING

PLATINUM DISSOLUTION

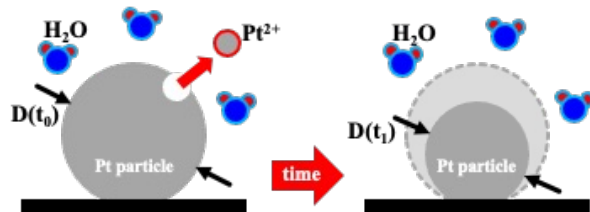

OSTWALD RIPENING

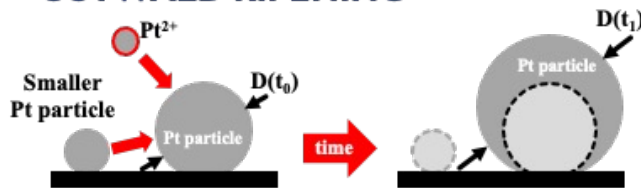

$$ECSA = \frac{u_{Pt} \pi}{A_{fc}} N_{Pt}(t) \bar{D}_{Pt}^2(t)$$

$$v(t) = \frac{ECSA(t) - ECSA(t - \Delta t)}{\Delta t}$$

CONTROL DESIGN

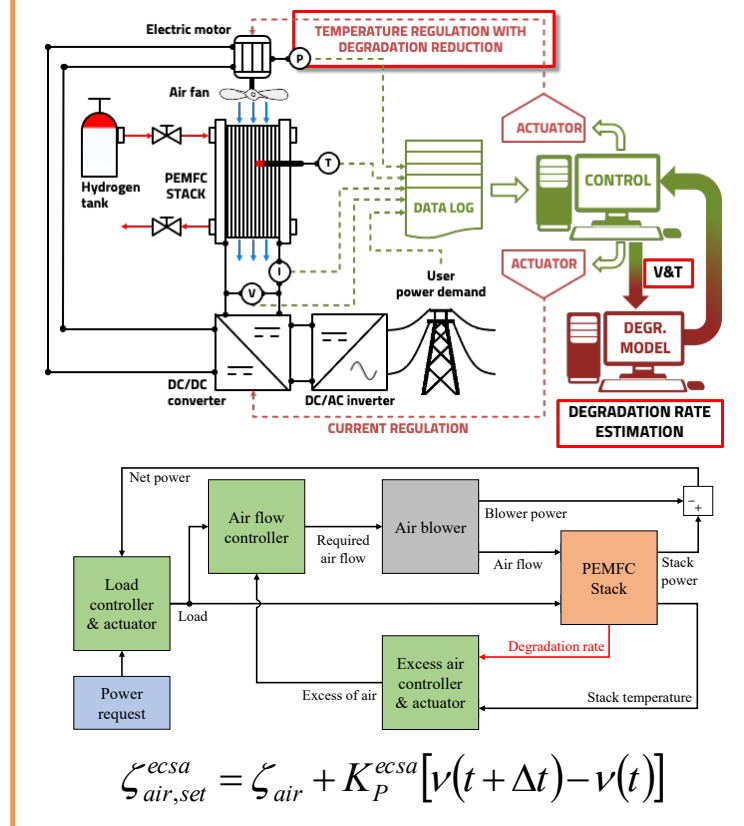

SIMULATION ANALYSIS

**Control Strategy #1 CS1 (baseline)**  
 Only control of temperature set point 45°C

**Control Strategy #2 CS2**  
 Only control of degradation

**Control Strategy #3 CS3**  
 Combined control of temperature and degradation

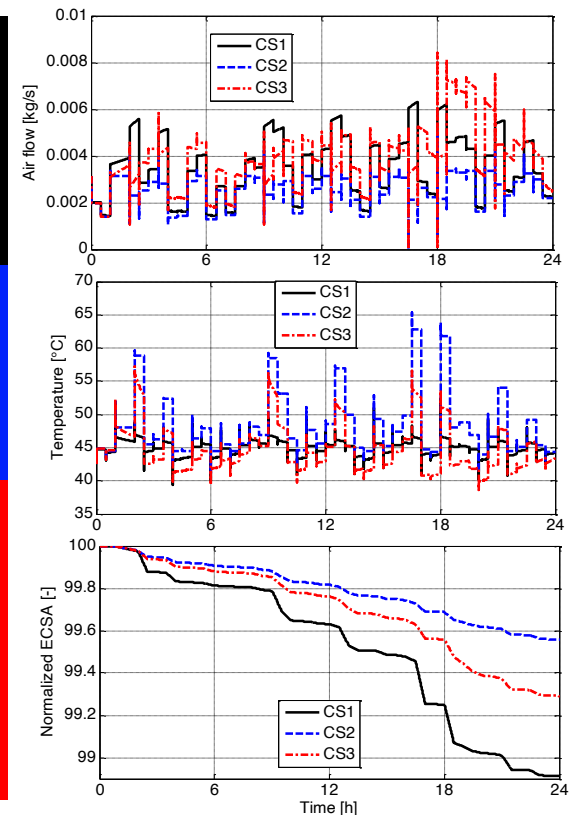

Polverino P., Pianese C., Model-based prognostic algorithm for online RUL estimation of PEMFCs, Proceedings of the 2016 3rd Conference on Control and Fault-Tolerant Systems (SysTol 2016), Barcelona, Spain, Sept. 7-9, 2016, pp. 599-604.  
 Polverino P., Pianese C., Control algorithm design for degradation mitigation and lifetime improvement of Polymer Electrolyte Membrane Fuel Cells, Energy Procedia 142 (2017) 1706-1713.



SOFC PERFORMANCE IMPROVEMENT THROUGH INNOVATIVE PRODUCTION PROCESS 1/2

Objective & Innovation

**Physical Vapour Deposition (PVD)** fabrication of Electrolyte/Cathode thin buffer layers in SOFCs to **reduce interdiffusion** due to the 700-900°C typical operation temperatures.



METHODOLOGY CONCEPT

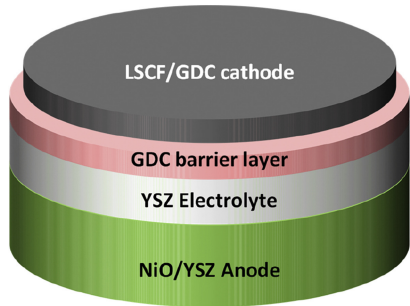

Thickness of 0.3-0.6 mm. and increased densities **improve cell performance and lowers temperatures** to 600-700°C.

Fabrication by room temperature RF Sputtering followed by in-air annealing at moderate temperatures **avoid heating cells** during deposition

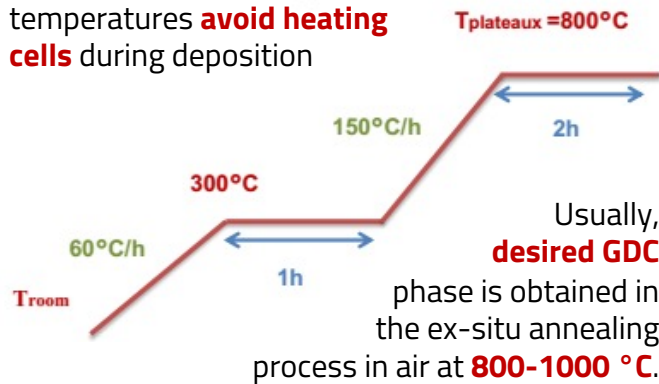

EXPERIMENTAL INVESTIGATION

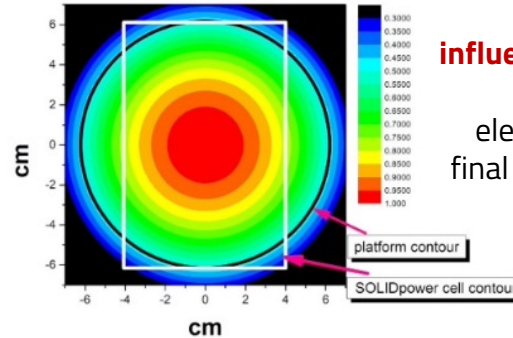
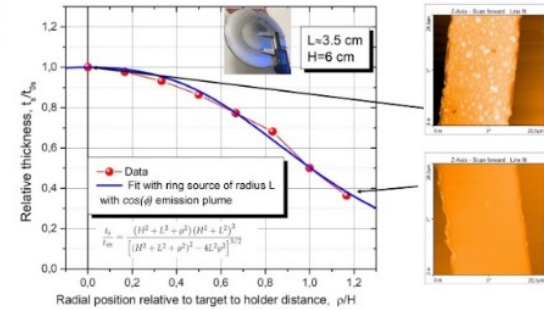
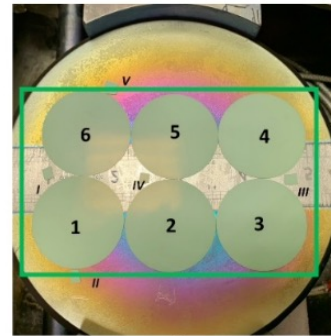

First we studied the **influence of the GDC thickness and thickness gradient** on the electrochemical properties of the final cells, simulating a large cell by positioning **6 cells under the sputtering target**

Due to the different thickness profile, the 6 cells had different total thickness and thickness gradient across their surfaces.

PERFORMANCE ANALYSIS

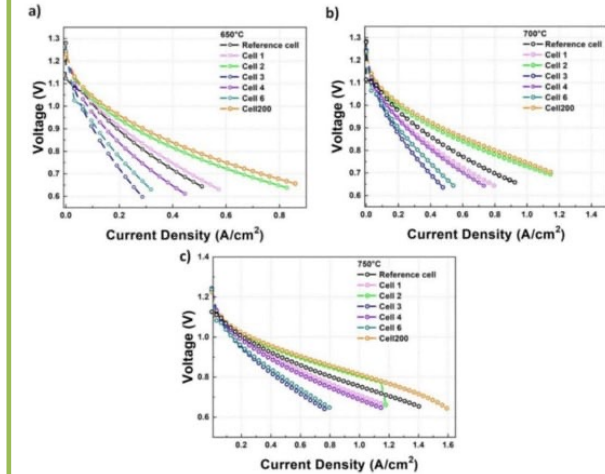

The j-V and EIS measurements showed the **thickness gradient across the cell** being the major factor influencing the **final cell performance**.

Compared to cells with screen printed GDC layer current densities measured on cells with sputtered GDC show **increase up to +60%** at 800 mV and 650 °C.

Coppola N., Rehman HSU, Carapella G., Polverino P., Montinaro D. Martinelli F., Granata V., Galdi A., Maritato L. Pianese C., "Large area solid oxide fuel cells with room temperature sputtered barrier layers: Role of the layer thickness and uniformity in the enhancement of the electrochemical performances and durability", International Journal of Hydrogen Energy 48 (2023) 30120-30131. DOI: 10.1016/j.ijhydene.2023.04.170.



## SOFC PERFORMANCE IMPROVEMENT THROUGH INNOVATIVE PRODUCTION PROCESS 2/2

## Objective &amp; Innovation

Assessment of GDC layer thickness uniformity and **scalability of the room temperature Sputtering process** for large (around 100 cm<sup>2</sup>) cells.



## METHODOLOGY COMPARISON

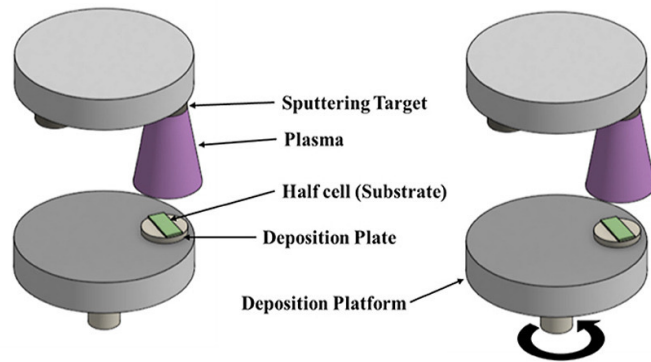

a) Static Mode

b) Dynamic Mode

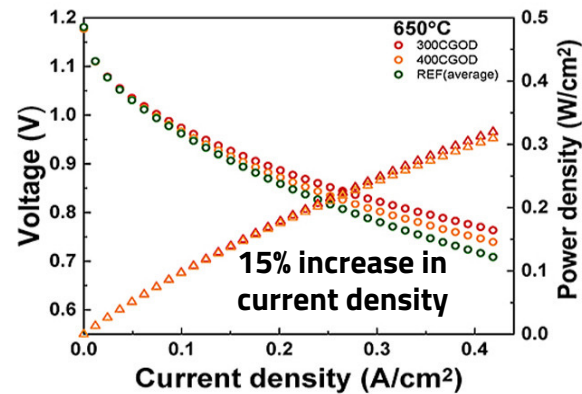

## NEW EXPERIMENTAL EQUIPMENT

New RF sputtering with **two large sources** (15x5 cm<sup>2</sup>) and a **movable substrate** platform has been received at UNISA to further study **industrial scalability** of the proposed deposition process.

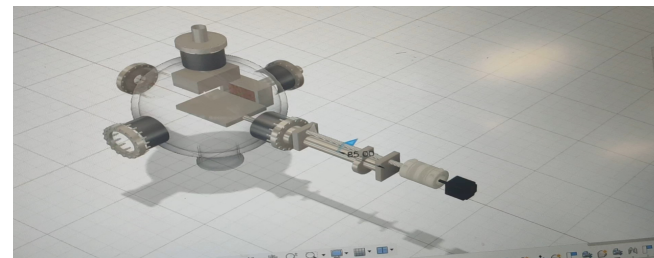
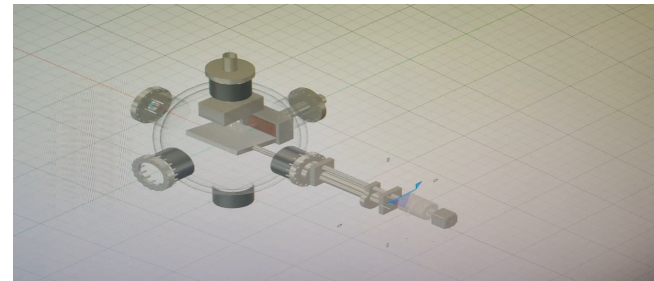

## LABORATORY INSTALLATION

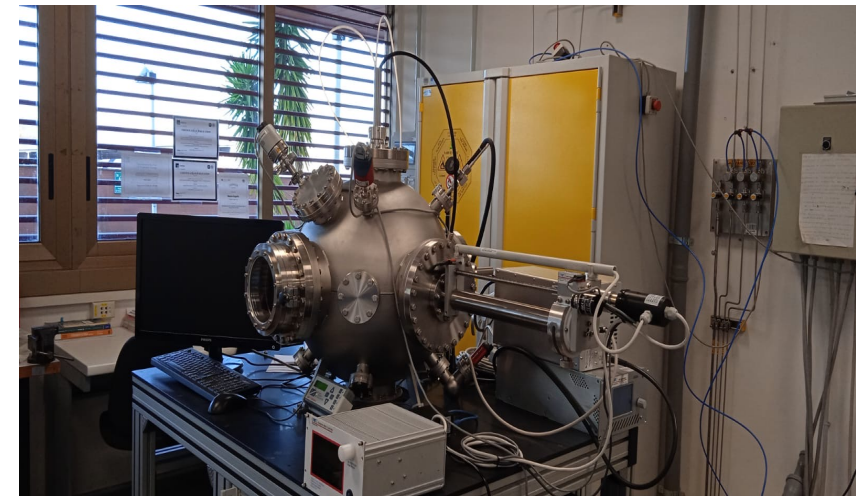

The **continuous motion** of cells during deposition emulates **continuous feeding** in industrial production lines.

The **two sputtering sources** can deposit simultaneously or in sequence two different ceramic materials, allowing fabrication of **multilayered and composite films**.

Coppola N., Morel B., Carapella G., Montinaro D., Galdi A., Rehman HSU, Polverino P., Pianese C., Mougín J., Maritato L., "Comparison of the Electrochemical Performances of Solid Oxide Fuel Cells with Sputtered Thin Barrier Layers Fueled by Hydrogen or Ammonia", Crystals 13 (2023) 1040. DOI 10.3390/cryst13071040.

HYDROGEN AS FUEL ADDITIVE IN ICE

Objective & Innovation

Investigate the energetic effectiveness of **on-board production of oxy-hydrogen** for usage as **fuel additive** in internal combustion engines for **fuel consumption reduction**.

MODELLING

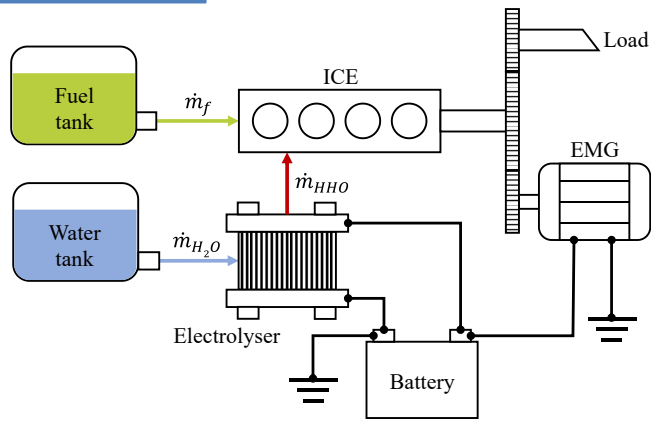

$$P_{Chem} = \dot{m}_f LHV_f + \dot{m}_{HHO} LHV_{HHO}$$

$$P_{ICE} = P_{Chem} \eta_{ICE} \quad P_{ICE} = P_L + P_{EMG}^g$$

$$P_{BATT}^g = P_{EMG}^g \eta_{EMG} \quad P_{HHO}^r = \dot{m}_{HHO} HHV_{HHO}$$

$$P_{ELEC}^g = P_{BATT}^g \eta_{BATT} \quad P_{HHO}^r = P_{EMG}^g \eta_{AUX}$$

$$P_{HHO}^r = P_{ELEC}^g \eta_{ELEC} \quad \eta_{AUX} = \eta_{EMG} \eta_{BATT} \eta_{ELEC}$$

ENERGETIC ANALYSIS

$$\underbrace{(\dot{m}_f LHV_f + \dot{m}_{HHO} LHV_{HHO}) \eta_{ICE}}_{P_{ICE}} = \underbrace{P_L}_{P_{AUX}} + \frac{P_{HHO}^r}{\eta_{AUX}}$$

$$\dot{m}_f = \frac{P_L}{LHV_f \eta_{ICE}} + \frac{P_{HHO}^r}{LHV_f} \left( \frac{1}{\eta_{ICE} \eta_{AUX}} - \alpha \right)$$

Term related to vehicle power request

Term related to HHO production

Term related to LHV change between H<sub>2</sub> and main fuel

$$\% \Delta \eta_{ICE} \geq \frac{(P_L - P_L^0) \eta_{AUX} + P_{HHO}^r (1 - \alpha \eta_{AUX} \eta_{ICE}^0)}{\eta_{AUX} (P_L^0 + \alpha P_{HHO}^r \eta_{ICE}^0)}$$

$\dot{m}_f < \dot{m}_f^0$   
**Unchanged Fuel Consumption Limit (UFCL)**  
 This term depends on power request and auxiliaries performance, but not influenced by fuel type.  
 $\% \Delta \eta_{ICE} \geq \delta$

ASSESSMENT OF LITERATURE

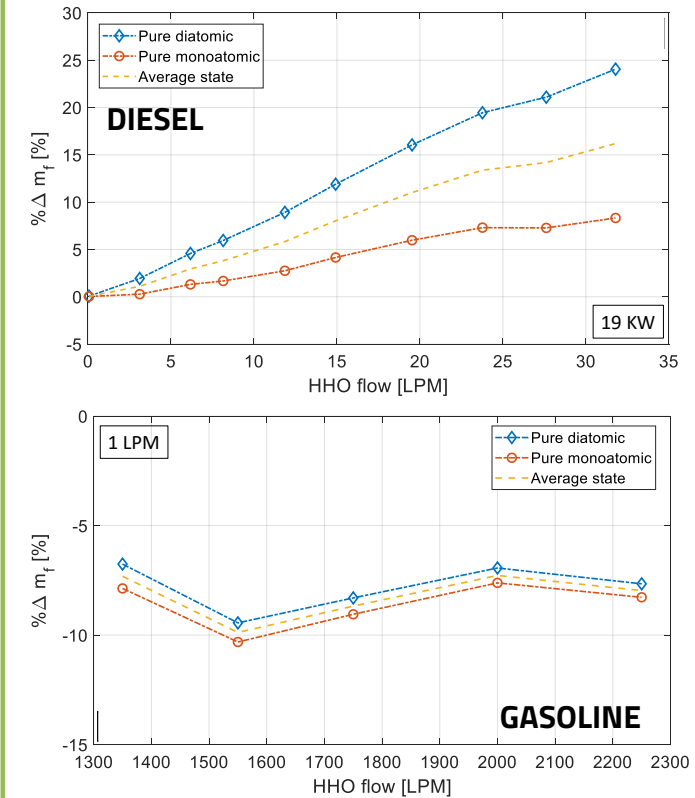

Polverino P., D'Aniello F., Arsie I., Pianese C., Study of the energetic needs for the on-board production of Oxy-Hydrogen as fuel additive in internal combustion engines, Energy Conversion and Management 179 (2019) 114-131



# HYDROGEN HYBRID VEHICLE ACTIVITIES

From design to supervisory control algorithms



PROGETTI DI RICERCA DI RILEVANTE INTERESSE NAZIONALE

From **pure electric vehicle** to **H<sub>2</sub> hybrid vehicle**

APU sized to **vehicle power needs**

Two possibilities: **H<sub>2</sub>-ICE** or **PEMFC**

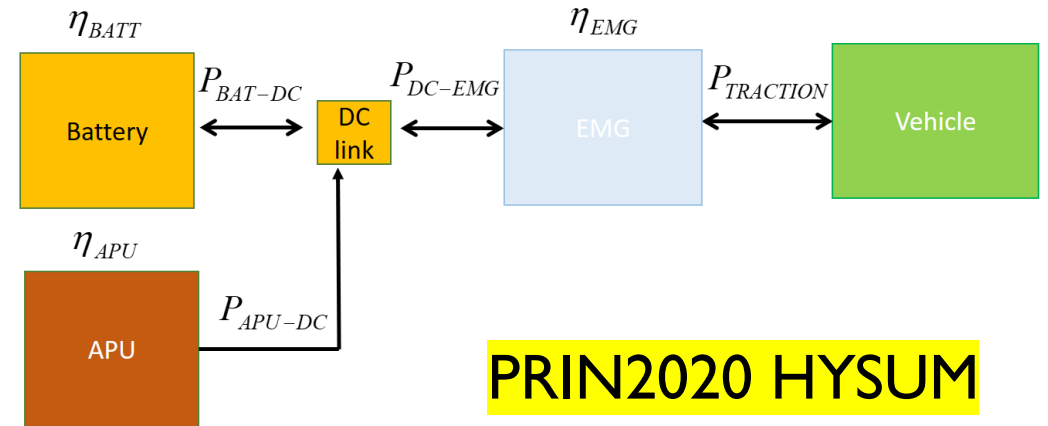

PRIN2020 HYSUM

## H<sub>2</sub>-ICE Range extender

H<sub>2</sub> engine

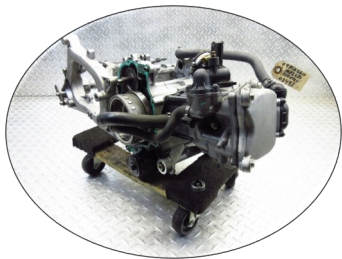

H<sub>2</sub>-ICE performances map

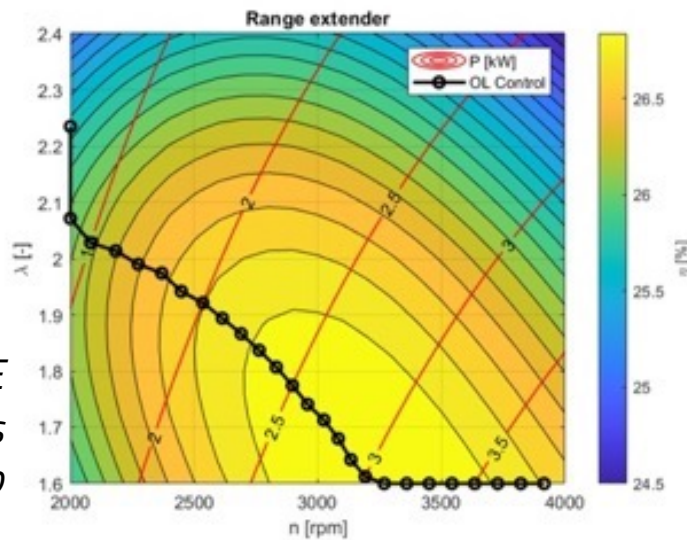

## PEMFC Range extender

PEMFC stack



PEMFC performances

PEMFC stack

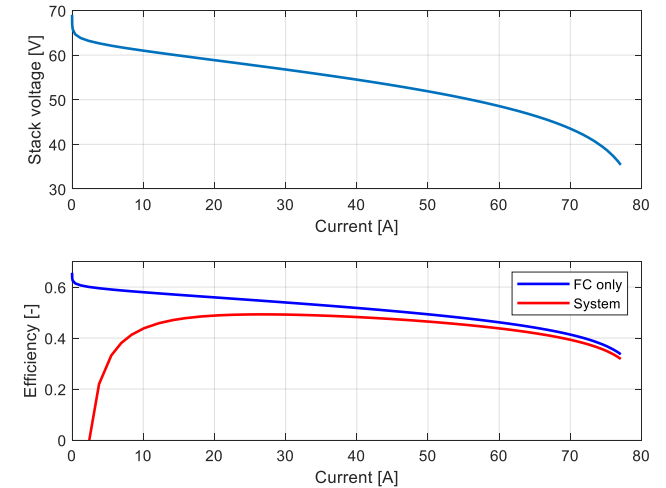

Cervone, Davide, et al. Modelling of a Hybrid Quadricycle (L6e vehicle) Equipped with Hydrogen Fueled ICE Range Extender and Performance Analysis on Stochastic Drive Cycles Generated from RDE Profile. SAE Technical Paper, 2023



# Supervisory control strategies development

## Causal approach (Rule-based)

**Objective:** controlling battery power to guarantee SOC rate with simple rules.

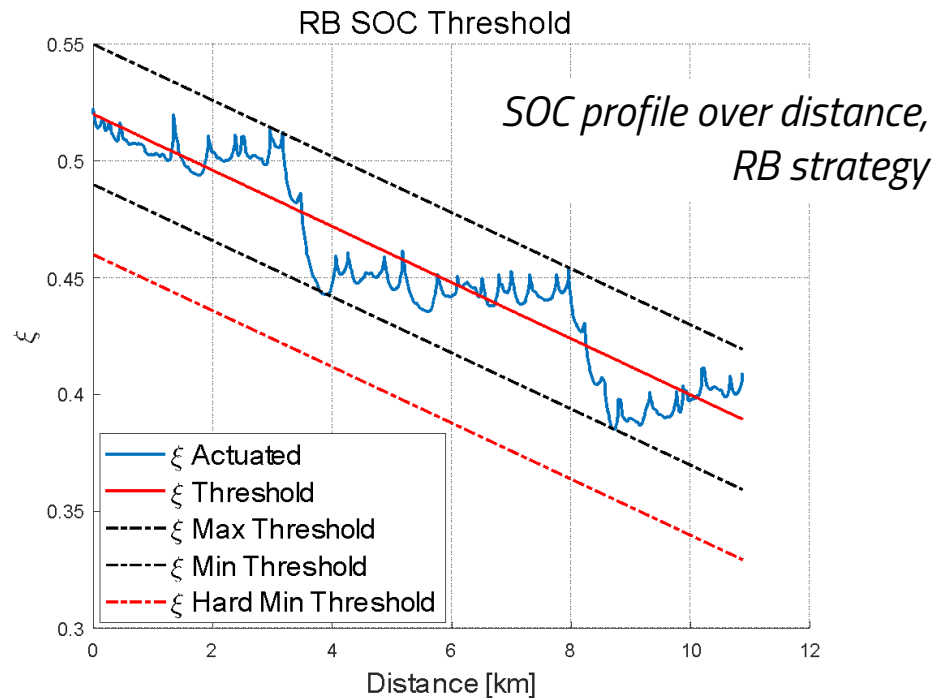

## Non causal approaches

**Objective:** find the SOC profile that minimizes fuel consumption according to constraints

DP

FADP

IFADP

PMP

ECMS

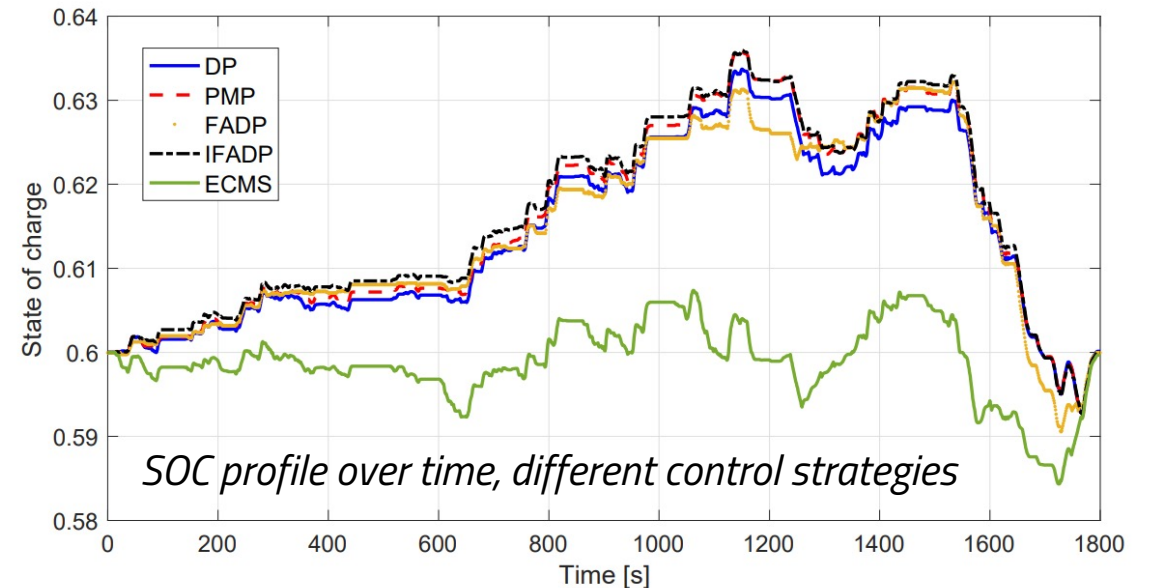

Donatantonio, Fabrizio, et al. Novel Approaches for Energy Management Strategies of Hybrid Electric Vehicles and Comparison with Conventional Solutions. Energies, 2022, 15.6: 1972.

# Hydrogen-fed telecom tower

An optimization procedure has been carried out to assess the **optimal design** and **year-through energy management** of a renewables and hydrogen-based microgrid considering both on-grid and off-grid scenarios.

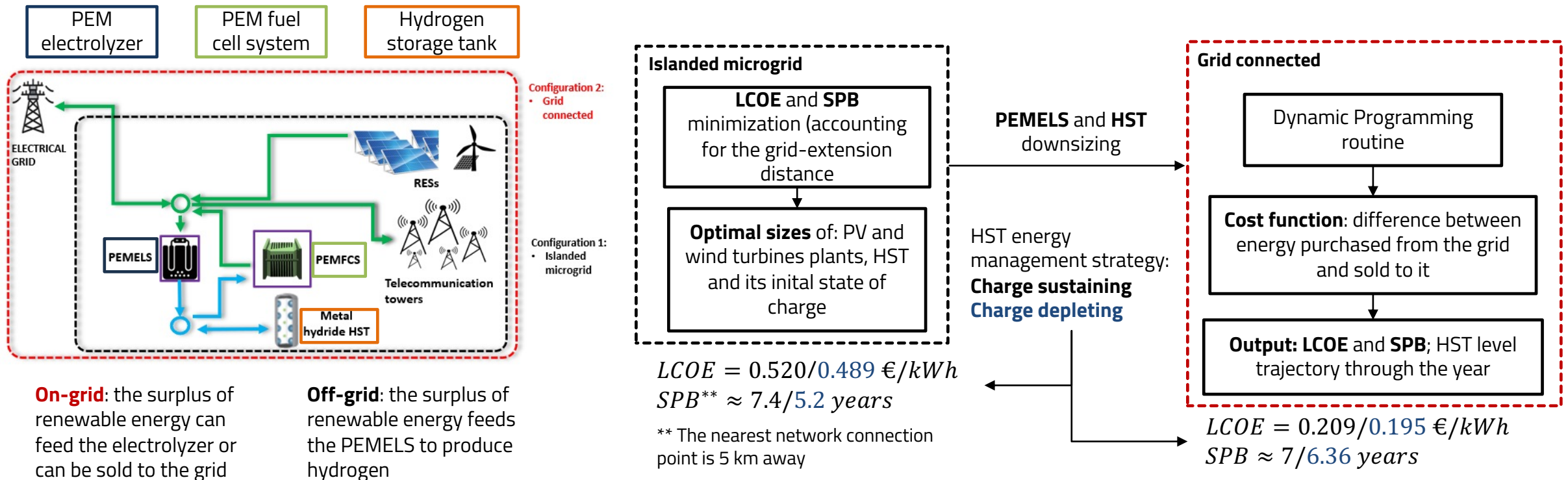

Aliberti, P., Sorrentino, M., Califano, M., Pianese, C., Capozucca, L., Cristiani, L., Lops, G., Mancini, R. Modelling Methodologies to Design and Control Renewables and Hydrogen-Based Telecom Towers Power Supply Systems. *Energies*, 16, 6316. 2023. <https://doi.org/10.3390/en16176316>.



# FCH aircraft design and control

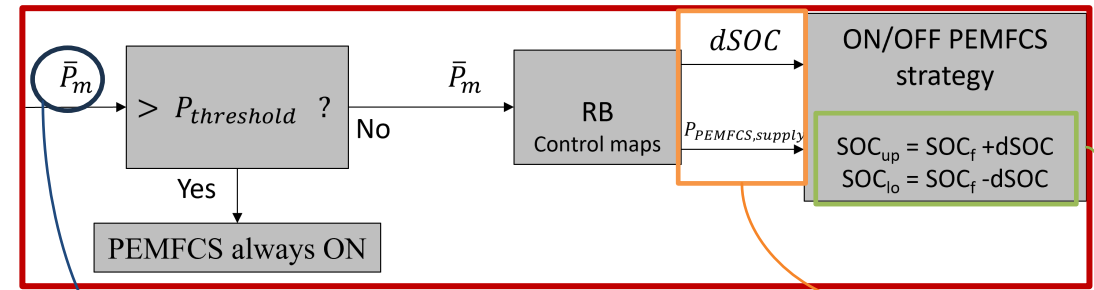
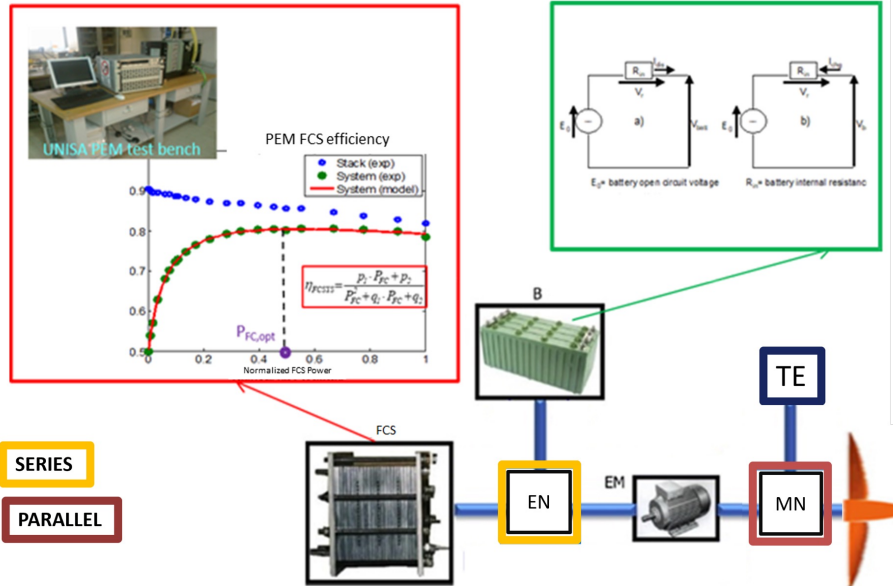

Average mission power evaluated over a given time horizon

Control variables: Battery state of charge variation (dSOC) and power supplied by the PEMFCS according to the maps

Battery SOC variation oscillating around a target value

$$P_{batt} = \frac{P_{EM}}{0,9} - P_{PEMFCS}; N_{BC} = \frac{P_{batt}}{P_{BC}}; DH_{electrical} = \frac{P_{batt}}{P_{EM}}; DH_{powertrain} = \frac{P_{EM}}{P_{EM} + P_{TE}};$$

The electrical part of a complete turboprop is considered and sized relying on a mathematical tool adapted from the automotive field.

A blended control strategy is embedded in the tool to associate an implementable control strategy for the PEMFCS system.

The methodologies and models here presented build the basis of the activities currently performed within the **HECATE** projec.



Sorrentino, M., Sparano, M., Troiano, G., Cerino, G., Piscopo, G., Basaglia, M., Pianese, C., 2023, The future technological potential of hydrogen fuel cell systems for aviation and preliminary co-design of a hybrid regional aircraft powertrain through a mathematical tool, Energy Conversion and Management, vol. 281, p. 116822, 2023.



PRIN22

 PROGETTI DI RICERCA DI  
 RILEVANTE INTERESSE NAZIONALE

# LYRICA



## Liquid hydrogen carriers as sustainable fuels for innovative energy systems configurations in the maritime sector

Prof.ssa Mariagiovanna Minutillo (PI)  
 University of Salerno

### Objectives

LYRICA aims to study, design and analyze innovative marine propulsion systems, based on modified engines and fuel cells fed by liquid hydrogen carriers like methanol and ammonia.

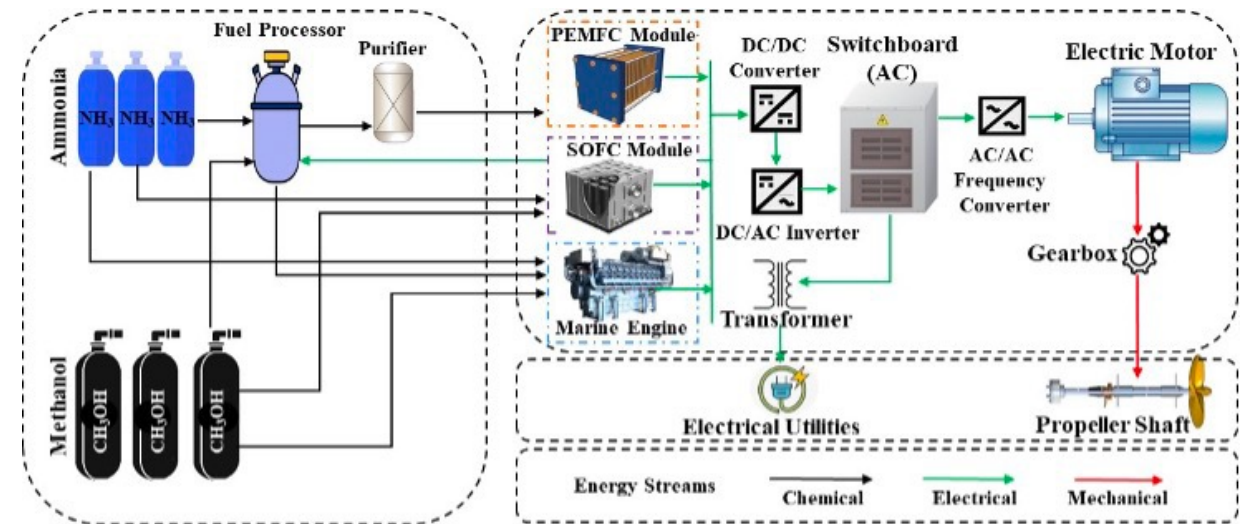

### Research activities

The research activities will be performed both at component-level, by means of numerical and experimental investigations, and at system-level by means of numerical approaches.

The simulations will regard the marine engines, the fuel cells units and the fuel processing systems.



PRIN PNRR

# SPHERA

## Sono-Photocatalysis for Hydrogen Engendering through Reactor Automation

Prof.ssa Mariagiovanna Minutillo  
University of Salerno



Project focus as part of the green hydrogen future scenery

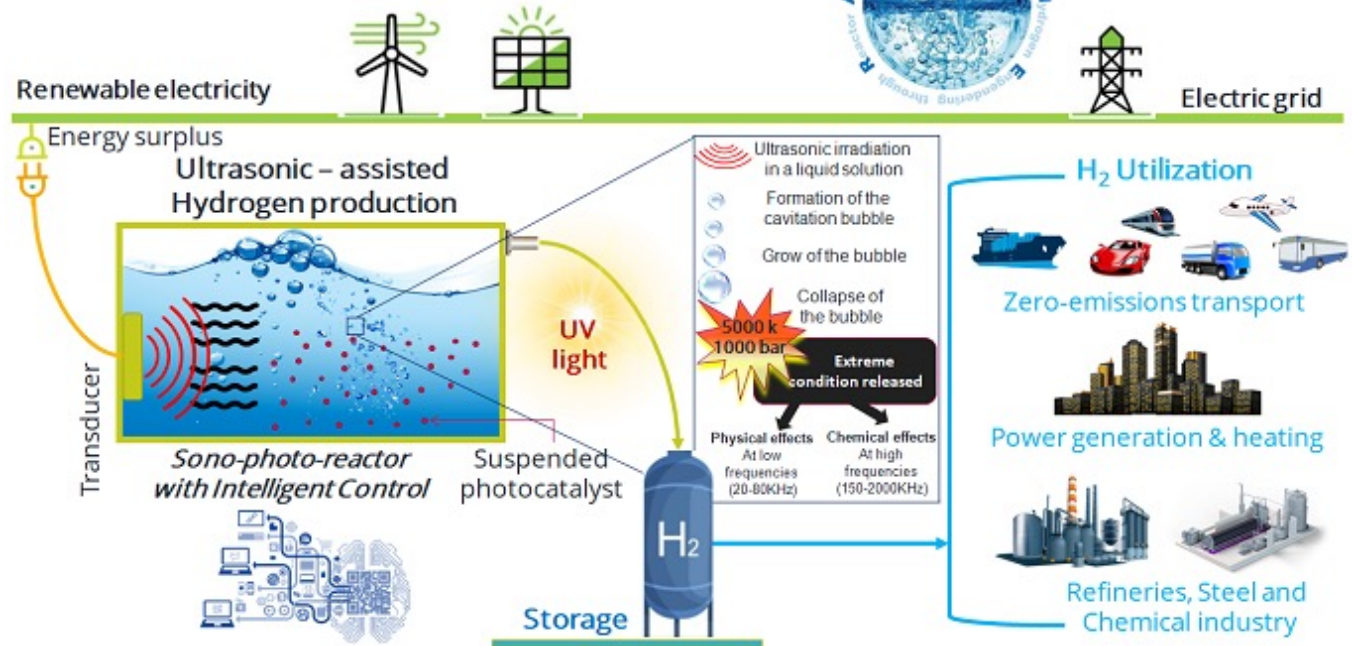

The SPHERA project investigates an innovative, unique, and smart platform to produce **green H<sub>2</sub>**. The main project concept is based on combining ultrasound power with heterogeneous photocatalysis in a single process unit powered only by renewable energy. In this regard, SPHERA will explore the potential of ultrasound technologies to engender hydrogen by mechanical stimulation of water using ultrasonic waves (20–1000kHz) and to address the main critical issues of photocatalysis pathway, represented by the lack of solar sensitivity and lower efficiency, especially in terms of H<sub>2</sub> production.



HORIZON-CL5-2021-D2-01-08

[www.fuelsome.eu](http://www.fuelsome.eu)

# FUELSOME

## Multifuel SOFC system with Maritime Energy vectors

Prof.ssa Mariagiovanna Minutillo  
University of Salerno

FuelSOME focuses on establishing the technological feasibility of a flexible, scalable, and multi-fuel capable energy generation system based on SOFC technology specially catered for long-distance maritime shipping. This system will be able to operate on Ammonia, Methanol and Hydrogen and their mixtures for which short and long-term sustainable supply pathways will be explored.



Participant No	Participant organisation name	Short name	Country
1	AVL LIST GMBH	AVL*	AT
2	AEE - INSTITUT FUR NACHHALTIGE TECHNOLOGIEN	AEE	AT
3	ATENA SCARL - DISTRETTO ALTA TECNOLOGIA ENERGIA AMBIENTE	ATENA	IT
4	EBOS TECHNOLOGIES LIMITED	EBOS	CY
5	ELCOGEN OY	ELCO*	FI
6	POLITECHNIKA WARSZAWSKA	WUT	PL
7	TEKNOLOGIAN TUTKIMUSKESKUS VTT OY	VTT*	FI
8	ZURCHER HOCHSCHULE FUR ANGEWANDTE WISSENSCHAFTEN	ZHAW	CH

Affiliated entity:  
University of Salerno



## RELEVANT PUBLICATIONS

- Aliberti P., Sorrentino M., Califano M., Pianese C., Capozucca L., Cristiani L., Lops G., Mancini R., Modelling Methodologies to Design and Control Renewables and Hydrogen-Based Telecom Towers Power Supply Systems. *Energies* 16 (2023) 6316. DOI: 10.3390/en16176316.
- Sorrentino, M., Sparano, M., Troiano, G., Cerino, G., Piscopo, G., Basaglia, M., Pianese, C., 2023, The future technological potential of hydrogen fuel cell systems for aviation and preliminary co-design of a hybrid regional aircraft powertrain through a mathematical tool, *Energy Conversion and Management*, vol. 281, p. 116822, 2023.
- Di Micco S., Mastropasqua L., Cigolotti V., Minutillo M., Brouwer J., A framework for the replacement analysis of a hydrogen-based polymer electrolyte membrane fuel cell technology on board ships: A step towards decarbonization in the maritime sector, *Energy Conversion and Management* 267 (2022) 115893.
- Perna A, Jannelli E, Di Micco S, Romano F, Minutillo M, Designing, sizing and economic feasibility of a green hydrogen supply chain for maritime transportation, *Energy Conversion and Management* 278 (2023) 116702.
- Adinolfi E., Gallo M., Polverino P., Beretta D., Araya S.S., Pianese C., ECM-based algorithm for on-board PEMFCs diagnosis, *Lecture Notes in Electrical Engineering* 697 (2020) 103-115.
- Polverino P., D'Aniello F., Arsie I., Pianese C., Study of the energetic needs for the on-board production of Oxy-Hydrogen as fuel additive in internal combustion engines, *Energy Conversion and Management* 179 (2019) 114-131. ISSN: 01968904. DOI: 10.1016/j.enconman.2018.09.082.
- Cervone, Davide, et al. Modelling of a Hybrid Quadricycle (L6e vehicle) Equipped with Hydrogen Fueled ICE Range Extender and Performance Analysis on Stochastic Drive Cycles Generated from RDE Profile. *SAE Technical Paper*, 2023.
- Donatantonio, Fabrizio, et al. Novel Approaches for Energy Management Strategies of Hybrid Electric Vehicles and Comparison with Conventional Solutions. *Energies*, 2022, 15.6: 1972.
- Polverino P., Pianese C., Control algorithm design for degradation mitigation and lifetime improvement of Polymer Electrolyte Membrane Fuel Cells, *Energy Procedia* 142 (2017) 1706-1713. Proceedings of the 9th International Conference on Applied Energy (ICAE2017), 21-24 August 2017, Cardiff, UK. ISSN: 18766102. DOI: 10.1016/j.egypro.2017.12.553.
- Polverino P., Pianese C., Model-based prognostic algorithm for online RUL estimation of PEMFCs, Proceedings of the 2016 3rd Conference on Control and Fault-Tolerant Systems (SysTol2016 - IEEE), 7-9 September 2016, Barcelona, Spain, pp. 599-604. ISSN: 21621195. DOI: 10.1109/SYSTOL.2016.7739814.
- Polverino P., Pianese C, Sorrentino M., Marra D., Model-based development of a fault signature matrix to improve solid oxide fuel cell systems on-site diagnosis, *Journal of Power Sources* 280 (2015) 320-338. ISSN: 03787753. DOI: 10.1016/j.jpowsour.2015.01.037.
- Coppola N., Rehman HSU, Carapella G., Polverino P., Montinaro D. Martinelli F., Granata V., Galdi A., Maritato L. Pianese C., "Large area solid oxide fuel cells with room temperature sputtered barrier layers: Role of the layer thickness and uniformity in the enhancement of the electrochemical performances and durability", *International Journal of Hydrogen Energy* 48 (2023) 30120-30131. DOI: 10.1016/j.ijhydene.2023.04.170.
- Coppola N., Morel B., Carapella G., Montinaro D., Galdi A., Rehman HSU, Polverino P., Pianese C., Mougín J., Maritato L., "Comparison of the Electrochemical Performances of Solid Oxide Fuel Cells with Sputtered Thin Barrier Layers Fueled by Hydrogen or Ammonia", *Crystals* 13 (2023) 1040. DOI 10.3390/cryst13071040.





UNIVERSITÀ DEGLI STUDI  
DI SALERNO



# THANKS FOR THE ATTENTION



**Pierpaolo Polverino**  
[ppolverino@unisa.it](mailto:ppolverino@unisa.it)



**Cesare Pianese**  
[pianese@unisa.it](mailto:pianese@unisa.it)



**Mariagiovanna Minutillo**  
[mminutillo@unisa.it](mailto:mminutillo@unisa.it)



**Marco Sorrentino**  
[msorrentino@unisa.it](mailto:msorrentino@unisa.it)

**Special thanks to:** prof. Luigi Maritato, prof. Alice Galdi, ing. Davide Cervone, ing. Massimo Sicilia, ing. Paolo Aliberti.

